

# ROTARY ENGINE 49-PI Type II

## INSTRUCTION MANUAL

It is of vital importance, before attempting to operate your engine, to read the general 'SAFETY INSTRUCTIONS AND WARNINGS' section on pages 2-6 of this booklet and to strictly adhere to the advice contained therein.

- Also, please study the entire contents of this instruction manual, so as to familiarize yourself with the controls and other features of the engine.
- Keep these instructions in a safe place so that you may readily refer to them whenever necessary.
- It is suggested that any instructions supplied with the aircraft, radio control equipment, etc., are accessible for checking at the same time.

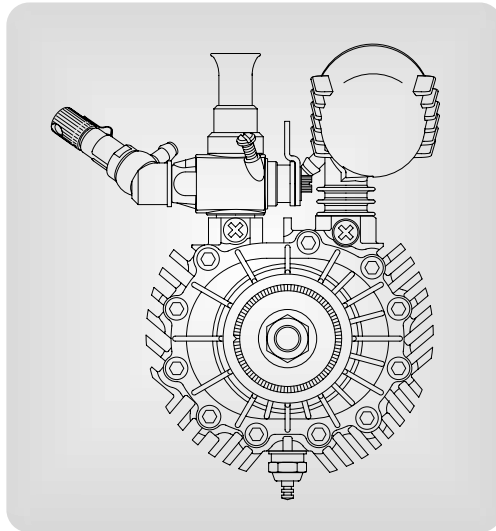

## O.S. ENGINE 49-PI Type II

### CONTENTS

SAFETY INSTRUCTIONS AND WARNINGS ABOUT YOUR O.S. ENGINE -----	2-6	STARTING THE ENGINE & RUNNING-IN ('Breaking') -----	21-25
ABOUT THE ENGINE -----	7-9	TROUBLE SHOOTING WHEN THE ENGINE FAILS TO START -----	26-27
BASIC ENGINE PARTS -----	10	CARE AND MAINTENANCE -----	28-29
BEFORE STARTING -----	11-14	ENGINE EXPLODED VIEWS & PARTS LIST -----	30-31
INSTALLATION OF THE STANDARD ACCESSORIES -----	15	CARBURETOR EXPLODED VIEWS & PARTS LIST -----	32-33
MIXTURE CONTROLS -----	16	O.S. GENUINE PARTS & ACCESSORIES -----	34
GLOWPLUG -----	17	THREE VIEW DRAWING -----	35
INSTALLATION OF THE ENGINE AND FUEL TANK -----	18-20	MEMO -----	36

## SAFETY INSTRUCTIONS AND WARNINGS ABOUT YOUR O.S. ENGINE

Remember that your engine is not a "toy", but a highly efficient internal-combustion machine whose power is capable of harming you, or others, if it is misused.

As owner, you, alone, are responsible for the safe operation of your engine, so act with discretion and care at all times.





If at some future date, your O.S. engine is acquired by another person, we would respectfully request that these instructions are also passed on to its new owner.

■ The advice which follows is grouped under two headings according to the degree of damage or danger which might arise through misuse or neglect.

 <b>WARNINGS</b>
<p>These cover events which might involve serious (in extreme circumstances, even fatal) injury.</p>

 <b>NOTES</b>
<p>These cover the many other possibilities, generally less obvious sources of danger, but which, under certain circumstances, may also cause damage or injury.</p>

2

 <b>WARNINGS</b>	
<ul style="list-style-type: none"> <li>● Never touch, or allow any object to come into contact with, the rotating propeller and do not crouch over the engine when it is running. </li> <li>● A weakened or loose propeller may disintegrate or be thrown off and, since propeller tip speeds with powerful engines may exceed 600 feet(180 metres) per second, it will be understood that such a failure could result in serious injury, (see 'NOTES' section relating to propeller safety).</li> <li>● Model engine fuel is poisonous. Do not allow it to come into contact with the eyes or mouth. Always store it in a clearly marked container and out of the reach of children. </li> </ul>	<ul style="list-style-type: none"> <li>● Model engine fuel is also highly flammable. Keep it away from open flame, excessive heat, sources of sparks, or anything else which might ignite it. Do not smoke or allow anyone else to smoke, near to it. </li> <li>● Never operate your engine in an enclosed space. Model engines, like automobile engines, exhaust deadly carbon-monoxide. Run your engine only in an open area.</li> <li>● Model engines generate considerable heat. Do not touch any part of your engine until it has cooled. Contact with the muffler (silencer), cylinder head or exhaust header pipe, in particular, may result in a serious burn. </li> </ul>

3



## NOTES

- This engine was designed for model aircraft. Do not attempt to use it for any other purpose.
- Mount the engine in your model securely, following the manufacturers' recommendations, using appropriate screws and lock-nuts.
- Be sure to use the silencer (muffler) supplied with the engine. Frequent exposure to an open exhaust may eventually impair your hearing. Such noise is also likely to cause annoyance to others over a wide area.
- If you remove the glowplug from the engine and check its condition by connecting the battery leads to it, do not hold the plug with bare fingers. Use an appropriate tool or a folded piece of cloth.
- Install a top-quality propeller of the diameter and pitch specified for the engine and aircraft. Locate the propeller on the shaft so that the curved face of the blades faces forward-i.e. in the direction of flight. Firmly tighten the propeller nut, using the correct size wrench.



## NOTES

- Always check the tightness of the propeller nut and retighten it, if necessary, before restarting the engine. Also, check the tightness of all the screws and nuts before restarting the engine.
- If you install a spinner, make sure that it is a precision made product and that the slots for the propeller blades do not cut into the blade roots and weaken them.
- Preferably, use an electric starter. The wearing of safety glasses is also strongly recommended.
- Discard any propeller which has become split, cracked, nicked or otherwise rendered unsafe. Never attempt to repair such a propeller: destroy it. Do not modify a propeller in any way, unless you are highly experienced in tuning propellers for specialized competition work such as pylon-racing.
- Take care that the glow plug clip or battery leads do not come into contact with the propeller. Also check the linkage to the throttle arm. A disconnected linkage could also foul the propeller.
- After starting the engine, carry out any needle-valve readjustments from a safe position behind the rotating propeller. Stop the engine before attempting to make other adjustments to the carburetor.



## NOTES

- Adjust the throttle linkage so that the engine stops when the throttle stick and trim lever on the transmitter are fully retarded. Alternatively, the engine may be stopped by cutting off the fuel supply. Never try to stop the engine physically.
- Take care that loose clothing (ties, shirt sleeves, scarves, etc.) do not come into contact with the propeller. Do not carry loose objects (such as pencils, screwdrivers, etc.) in a shirt pocket from where they could fall through the propeller arc.
- Do not start your engine in an area containing loose gravel or sand. The propeller may throw such material in your face and eyes and cause injury.
- For their safety, keep all onlookers (especially small children) well back (at least 20 feet or 6 meters) when preparing your model for flight. If you have to carry the model to the take-off point with the engine running, be especially cautious. Keep the propeller pointed away from you and walk well clear of spectators.
- Warning! Immediately after a glowplug-ignition engine has been run and is still warm, conditions sometimes exist whereby it is just possible for the engine to abruptly restart if the propeller is casually flipped over compression WITHOUT the glowplug battery being reconnected. Remember this if you wish to avoid the risk of a painfully rapped knuckle!

## **O.S.**ENGINE 49-PI Type II

### ABOUT THE ENGINE

The O.S. rotary combustion engine, based on NSU/Wankel System, was the world's first production model engine of the rotary-piston type as invented by Felix Wankel in 1957 and produced by NSU/Wankel in 1959. This highly successful application of the NSU/Wankel System to a power unit of miniature proportions, has only been made possible by the expertise of O.S. research and development engineers and by the high levels of precision craftsmanship achieved in its tooling and manufacture.

#### Operating principle

In place of the piston and cylinder of a conventional reciprocating engine, the Wankel motor has a three-lobe rotor which moves in a circular path, while rotating about its own axis, within a housing having

an epitrochoidal bore – i.e. a wide-waisted figure eight shape. Planetary rotation is controlled by an eccentric shaft, an internally-toothed gear and a fixed pinion mounted centrally on the rear cover plate. The tips of the rotor are in continuous contact with the housing, forming three chambers, each of which changes in volume, with rotation, to effect suction, compression, expansion and exhaust phases, as in a four-stroke reciprocating engine. Spring-loaded tip seals on the rotor prevent gases from passing from one chamber to the adjoining one and the rotor uncovers ports, as in a two-stroke engine, to control intake and exhaust timing.

**Features**

- Almost total freedom from vibration  
Relatively low noise level Pleasant sound specific to a rotary engine
- Compact shape which enables easier installation in most models
- Commercially available top-quality model engine fuel containing 18% oil, either synthetic or castor, can be used.

**Note**

**Do not use commercially available low oil content fuel.**

**Since this is a rotary engine designed for model application, there are some notes to be followed in order to run it well for a long time. Also, handling of this engine is somewhat different from that of two-stroke and four-stroke engines.**

1. Start the engine with an electric starter. Hand starting can be difficult due to the fuel mixture not having direct access to the glowplug, i.e. the glowplug does not extend into the combustion chamber and access is by means of a small hole in the housing.
2. Starting is difficult when the atmospheric temperature is below 10°C. In this case, warm the engine to approx. 20°C.

3. Prime the engine fairly liberally with fuel and turn the propeller more than 3 turns so that all three chambers are primed. Start the engine in a short time (1~2 seconds). Prolonged application of an electric starter (more than 4 seconds) without engine firing will cause seizing between the side housing and the rotor due to insufficient lubrication. (Without firing, the fuel does not have sufficient lubricating as the oil in the fuel is diluted with methanol and additives.)
4. Try to set the needle-valve with one trial. Setting on the ground lacks sufficient cooling, and the engine easily overheats.
5. When the engine is enclosed in a cowl, be sure to make ventilation holes (outlet hole Should be larger than inlet hole.), or the engine will overheat, which results in poor engine running or possible seizing.
6. Do not remove the carburetor intake tube, or the engine setting may vary, which results in poor running.

**OS ENGINE** 49-PI Type II

**BASIC ENGINE PARTS**

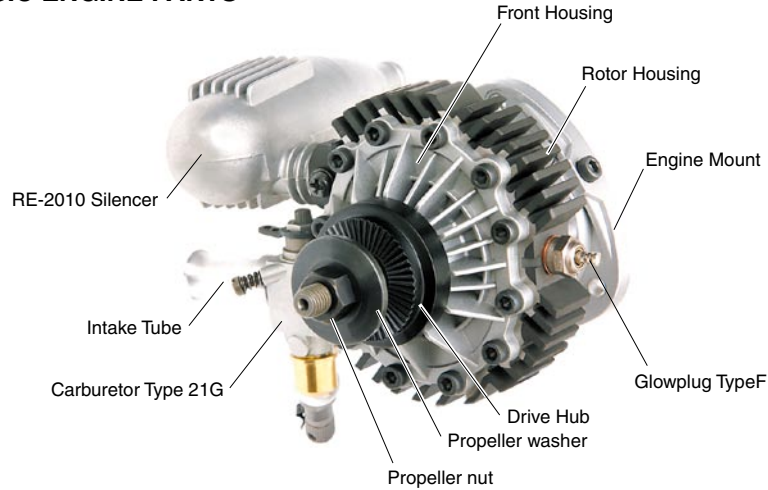

**OS ENGINE** 49-PI Type II

**BEFORE STARTING**

Tools, accessories, etc. The following items are necessary for operating the engine.

**GLOW PLUG**

O.S. TypeF glowplug is supplied with the engine.



**GLOWPLUG IGNITER**

Commercially available handy glowplug heater in which the glowplug battery and battery leads are integrated.

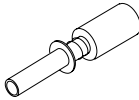

**FUEL PUMP**

Alternatively, one of the purpose-made manual or electric fuel pumps may be used to transfer fuel directly from your fuel container to the fuel tank.

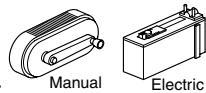

**FUEL**

For this engine, use top quality methanol-based model engine fuel containing more than 18% oil either synthetic or castor and between 5% and 15% nitromethane.

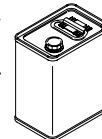

**Reminder!**

- ⚠ Model engine fuel is poisonous. Do not allow it to come into contact with the eyes or mouth. Always store it in a clearly marked container and out of the reach of children.
- ⚠ Model engine fuel is also highly flammable. Keep it away from open flame, excessive heat, sources of sparks, or anything else which might ignite it. Do not smoke, or allow anyone else to smoke, near to it.

**Electric Starter and Starter Battery**

Required when starting the engine.

12-Volt lead-acid battery

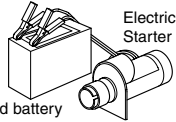

**Fuel Filter**

It is recommended to install a good in-line filter between the fuel tank and carburetor to prevent entry of foreign matter into the carburetor.

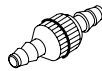

**O.S. Super Filter (Fuel Can Filter)**

Install a filter on the outlet tube of your refueling container to prevent entry of foreign matter into fuel tank. O.S. 'Super Filters' (large and small) are available as optional extras.



**O.S. Non-Bubble Weight S**

The engine is supplied with a small size Non-Bubble Weight. Be sure to use it in a fuel tank installed in a model.



Since the distance from the carburetor to the expansion chamber in the housing is very short with a rotary engine, even a tiny bubble from the fuel tank will cause engine misfiring. The Non-Bubble Weight will prevent this.

This Non-Bubble Weight can be used for all reciprocating engines. It is especially suitable for helicopter engines and big engines which generate bubbles due to vibration. Also, it is suitable for helicopter sub tanks due to the small dia. of 10mm.

**Fuel Tank**

A fuel tank of approximately 320cc capacity is suggested. This allows around 10-12 minutes flying time, dependent upon the type of fuel used, the size of propeller and on the amount of full-throttle to part-throttle operation throughout the flight.

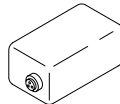

**Spinner**

Since the 49-PI is intended to be started with an electric starter, the addition of a spinner assembly for centering the starter sleeve is desirable. Use a heavy-duty, well balanced spinner either of metal or plastic.



**SILICONE FUEL LINE**

Heatproof silicone tubing of approx. 5mm o.d. and 2.5mm i.d. is required for the connection between the fuel tank and engine.

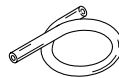

**Propellers**

The choice of propeller depends on the design and weight of the aircraft and the type of flying in which you will be engaged.

Determine the best size and type after practical experimentation. As a starting point, refer to the props listed in the accompanying table. Slightly larger, or even slightly smaller, props than those shown in the table may be used, but remember that the propeller noise will increase, due to higher rpm or if a larger-diameter/lower-pitched prop is used.

SIZE (DxP)
9x6-7, 10x4-6, 11x4-5

The above propeller sizes are just for a guide.

**Warning:**

Make sure that the propeller is well balanced. An unbalanced propeller and/or spinner can cause serious vibration which may weaken parts of the airframe or affect the safety of the radio-controlled system. DO NOT forget the WARNINGS and NOTES on propeller and spinner safety given in the front pages.

**Reminder!**

 Never touch, or allow any object to come into contact with, the rotating propeller and do not crouch over the engine when it is running.

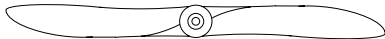

**Model**

Suitable model is the one designed for two-stroke 32-40 size engines. (Guide weight 2,000~2,500g)

**INSTALLATION OF THE STANDARD ACCESSORIES**

**STANDARD ACCESSORIES**

- Glow Plug Type F (installed on the engine)
- RE-2010 Silencer Assembly
  - Silencer Body
  - Pressure Nipple (No.7)
  - Silencer Retaining Screw
- Non-Bubble Weight S



**■ INSTALLING THE GLOWPLUG**

Install washer on glowplug and insert carefully into rotor-housing, making sure that it is not cross-threaded before tightening firmly.

**■ INSTALLING SILENCER**

Be sure to apply silicone sealant at the joint of silencer and engine and also use spring washers when fastening retaining screws.

Carburetor is designed to use a muffler pressurized fuel feed system. Avoid big fuel level difference, and be sure to use a muffler pressure.

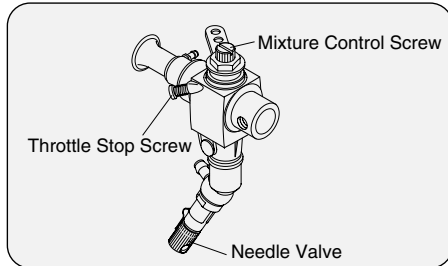

**MIXTURE CONTROLS**

**Two mixture controls are provided on this Carburetor.**

**The Needle Valve**

When set to produce maximum power at full throttle, this establishes the basic fuel/air mixture strength. The correct mixture is then maintained by the carburetor's built-in automatic mixture control system to cover the engine's requirements at reduced throttle settings.

**The Mixture Control Screw**

This meters fuel flow at part-throttle and idling speeds to ensure reliable operation as the throttle is opened and closed. The Mixture Control Valve is factory set for the approximate best result. First run the engine as received and readjust the Mixture Control Screw only if necessary.

Mixture Control Screw of the carburetor is set at basic position ( a little on the rich side) at the factory. However, minor readjustment will be required for a fuel used, atmospheric conditions and a model. Please note during a running-in period flights should be made with a slightly rich needle setting. Therefore, during a running-in period proper carburetor responses will not be obtained. Adjust it at optimum position after the running-in is completed.

**GLOWPLUG**

Since the compatibility of the glowplug and fuel may have a marked effect on performance and reliability, it is suggested to use the O.S. Type F plug when it is necessary to replace. Carefully install plug finger-tight, before final tightening with the correct size plug wrench.

**The role of the glowplug**

With a glowplug engine, ignition is initiated by the application of a 1.5-volt power source. When the battery is disconnected, the heat retained within the combustion chamber remains sufficient to keep the plug filament glowing, thereby continuing to keep the engine running. Ignition timing is 'automatic' : under reduced load, allowing higher rpm, the plug becomes hotter and, appropriately, fires the fuel/air charge earlier; conversely, at reduced rpm, the plug become cooler and ignition is retarded.

**Glowplug life**

Particularly in the case of very high performance engines, glowplugs must be regarded as expendable items. However, plug life can be extended and engine performance maintained by careful use, i.e.:

- Install a plug suitable for the engine.
- Use fuel containing a moderate percentage of nitromethane unless more is essential for racing events.
- Do not run the engine too lean and do not leave the battery connected while adjusting the needle.

**When to replace the glowplug**

Apart from when actually burned out, a plug may need to be replaced because it no longer delivers its best performance, such as when:

- Filament surface has roughened and turned white.
- Filament coil has become distorted.
- Foreign matter has adhered to filament or plug body has corroded.
- Engine tends to cut out when idling.
- Starting qualities deteriorate.

## OS ENGINE 49-PI Type II

### INSTALLATION OF THE ENGINE AND FUEL TANK

Use the engine mount supplied with the engine to install the engine in the model.

- Decide the installation position. Any direction will do.

- Set the fuel tank position so that the carburetor center line is 1/3 lower than from the tank top when the model is placed horizontal.
- Locate the fuel tank as close as to the carburetor, or the fuel level difference will affect the engine running when the model is upright or inverted.

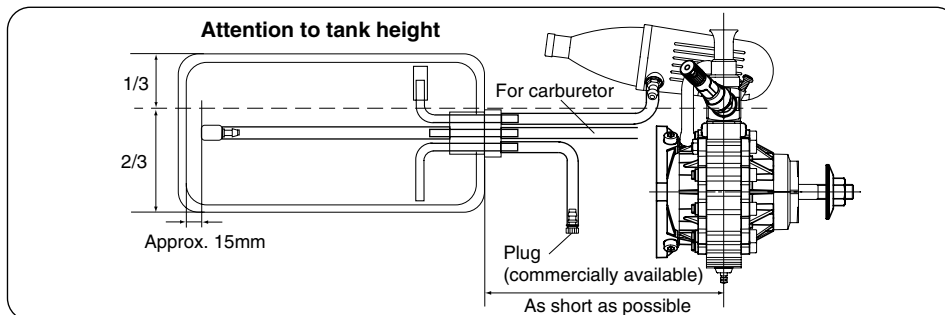

18

## OS ENGINE 49-PI Type II

- After deciding the installation position and direction, remove the engine mount from the engine by removing three retaining screws.
- Firmly bolt the engine's radial mounting flange to the model with 4mm or 3.5mm screws and self-locking nuts.

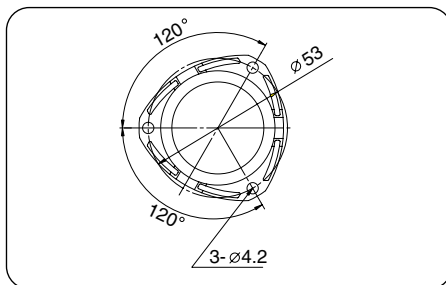

19

### ■ THROTTLE LINKAGE

Before connecting the throttle to its servo, make sure that the throttle arm and linkage safely clear any adjacent part of the airframe structure, etc., as the throttle is opened and closed. Connect the linkage so that the throttle is fully closed when the transmitter throttle stick and its trim lever are at their lowest settings and fully open when the throttle stick is in its fully-open position. Carefully align the appropriate holes in the throttle arm and servo horn so that they move symmetrically and smoothly through their full travel.

### ■ NEEDLE-VALVE EXTENSION

The needle-valve supplied with this engine is designed to incorporate an extension so that, when the engine is enclosed within the fuselage, the needle-valve may be adjusted from the outside. For this purpose, a Needle Valve Extension Cable Set is supplied with the engine. If a longer extension is required, cut a commercially available rod to the required length, bend one end to an L shape, insert it into needle's center hole and secure it by tightening the set-screw in the needle-valve knob with 1.5mm Allen key.

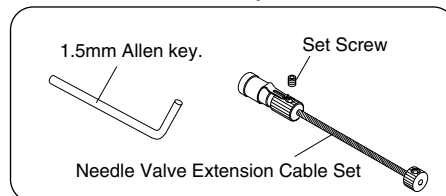

20

## STARTING THE ENGINE & RUNNING-IN ('Breaking-in')

Be sure to use an electric starter to start the engine.

⚠ **Never fail to check the tightness of screws and nuts, especially engine mounting and moving parts (e.g. throttle lever).**

**Starting procedure is as follows:**

1. Fill the fuel tank with fuel. When filled, prevent fuel flowing into the carburetor with a commercially available fuel stopper, etc. Release the stopper before starting the engine.
2. Make sure that plug element glows red, and install the plug in the rotor housing.

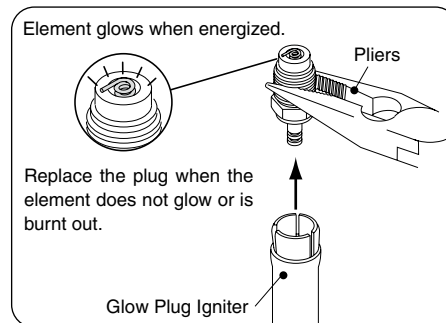

### WARNING

**When checking the plug element hold the plug with tools, such as pliers, etc. Do not hold near your face or the fuel remaining in the filament may burn you.**

21

3. Check that the needle-valve is closed. (Do not overtighten.) Now open the needle-valve counter-clockwise 2 turns to the starting setting.

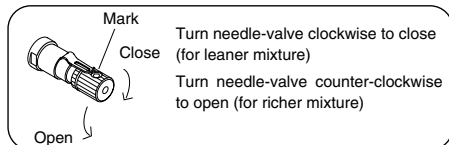

4. Open the throttle fully and deliver fuel to the carburetor by applying an electric starter for a very short time.
5. Set the throttle valve at 1/3 open from fully closed position.

6. Connect battery leads to glowplug.

7. Bring electric starter into contact with spinner-nut or spinner and depress starter Switch for one to two seconds. Repeat if necessary. When the engine starts, withdraw the starter immediately.

8. When the engine is running, open the throttle slowly to full open. Run the engine 5-6 seconds without changing needle-valve position. If the r.p.m. is low due to a rich mixture, close the needle-valve a little.

9. Now disconnect battery leads and close the needle-valve slowly one click at a time. Abrupt closing may stop the engine specially when the engine is new and running-in is incomplete.

**Attention :**

Do not choke the carburetor air intake when applying the starter. This could cause an excessive amount of fuel to be drawn into the cylinder which may initiate an hydraulic lock and damage the engine.

If the engine does not start within 10 repeat applications of the starter, remove the glow-plug, check that it glows brightly and that the cylinder is not flooded with fuel. (To eject excess fuel, close needle-valve and apply starter with glowplug removed.) Then try again.

**VERY IMPORTANT!**

Before being operated at full power (i.e. at full-throttle and with the needle-valve closed to its optimum setting) the engine must be adequately run-in, otherwise there is a danger of it becoming overheated and damaged.

**How to stop the engine**

Pull down the throttle lever and trim lever on the transmitter fully.

**Note:**

**Make sure that the throttle linkage is made so that the throttle is fully closed when the throttle lever as well as trim lever on the transmitter are fully pulled down.**

**RUNNING-IN ("Breaking-in")**

For running-in, fit the engine with a well-balanced propeller intended for actual flight. Use a fuel mixture as specified. Running-in procedure is the same as for a conventional reciprocating model engine. After starting the motor, open the throttle fully, but use a rich needle-valve setting to reduce rpm, increase lubrication and lower running temperature. This will produce a smoky exhaust but will ensure that the engine does not become overheated and damaged during this critical period.

1. Install the engine with the propeller intended for your model. Run the engine for one minute with the throttle fully open, but with the needle-valve adjusted for rich, slow "four-cycle" operation. Then, adjust the needle-valve so that the engine just breaks into "two-cycle" from "four-cycle" operation, and run the engine for 2 tanks. If the r.p.m. fall off, the needle-valve is closed a little too much and the mixture should be richened.
2. Fly the model with rich needle-valve setting. The needle-valve can be gradually closed after each flight to give more power. However, if the engine shows signs of running too lean, the next flight should be set rich. Avoid successive "nose-up" flights.
3. After a total of ten flights, the engine should run continuously, on its optimum needle-valve setting, without loss of power as it warms up.

**■ SUBSEQUENT READJUSTMENT**

Once the engine has been run-in and the controls properly set up, it should be unnecessary to alter the mixture settings; except to make minor adjustments to the Needle-Valve occasionally, to take account of variations in climatic conditions. The use of a different fuel, however, particularly one containing more, or less, nitromethane and/or a different type or proportion of lubricating oil, is likely to call for some readjustment of the Needle-Valve. Remember that, as a safety measure, it is advisable to increase the Needle-Valve opening by an extra half-turn counter-clockwise, prior to establishing a new setting. The same applies if the silencer type is changed. A different silencer may alter the exhaust pressure applied to the fuel feed and call for a revised Needle-Valve setting. The use of a different glowplug may also require compensating carburetor readjustments.

**■ CARBURETOR CLEANLINESS**

The correct functioning of the carburetor depends on its small fuel orifices remaining clear. The minute particles of foreign matter that are present in any fuel, can easily partially obstruct these orifices and upset mixture strength so that engine performance becomes erratic and unreliable.

O.S.'Super-Filters'(large and small) are available, as optional extras, to deal with this problem. One of these filters, installed on the outlet tube inside your refueling container, will prevent the entry of foreign material into the fuel tank. It is also recommended that a good in-line filter be installed between the tank and needle-valve. Do not forget to clean the filters regularly to remove dirt and lint that accumulate on the filter screen.

Also, clean the carburetor itself occasionally.

**TROUBLE SHOOTING WHEN THE ENGINE FAILS TO START**

**Four key points**

For quick, reliable starting, the following four conditions are required.

- ① **Good compression.**
- ② **Adequate "glow" at glowplug.**
- ③ **Correct mixture.**
- ④ **Sufficient electric starter rotating speed.**

If the engine fails to start, or does not keep running after being started, check symptoms against the following chart and take necessary corrective action.

**Note:** The most common causes of trouble are marked with three asterisks, the less common problems with one or two asterisks.

Symptom	Factor	Cause	Corrective action
Engine fails to fire.	①	★ Sluggish rotation . . . . .	Recharge the electric starter battery.
		★★ Glowplug battery discharged. . . . .	Recharge lead-acid cell or replace dry battery. (Note: An unused, or almost unused, dry battery may sometimes be of insufficient capacity if it is "old stock".)
	②	★ Glowplug element is burned out . . . . .	Replace glowplug. Check that applied voltage is not too high.
		★ Something wrong with battery leads. . . . .	Check glowplug heating using other leads.
	③	★★ Engine "flooded" due to excessive priming. . . . .	Close needle-valve fully and remove glowplug, then flip propeller to pump out excess fuel. (Invert engine, if possible, while pumping out excess). Re-start engine. (Priming is not necessary at this time.)
		★ Insufficient priming. . . . .	Repeat priming procedure referring to Priming.

Symptom	Factor	Cause	Corrective action
Engine fires intermittently but does not run.	②	★★ Incorrect heating of glowplug. . . . .	Voltage too high or too low. Re-check and readjust referring to "BEFORE STARTING".
		③	★★ Over priming. . . . .
	①	★ Sluggish rotation. . . . .	Then re-start. (Priming is not necessary.) Recharge the electric starter battery.
Engine fires once or twice, then fails to fire.	②	★★ Glowplug battery discharged. . . . .	Recharge lead-acid cell or replace dry battery. (Note: An unused, or almost unused, dry battery may sometimes be of insufficient capacity if it is "old stock".)
Engine starts but rpm decreases and engine eventually stops.	③	★★ Insufficient priming. . . . .	Repeat priming procedure referring to Priming.
Engine starts, rpm increases and engine cuts out.	③	★★★ Mixture too rich. . . . .	Close needle-valve half turn (180°) and wait for several minutes then re-start.(Priming is not necessary.)
Engine stops when the current to the glowplug is disconnected after starting	③	★ Fuel not reaching the engine. . . . .	Make sure that tank is filled with fuel. Check that there is not something wrong with the fuel line (kinked or split). Check that carburettor is not clogged with dirt.
	③	★★ Mixture too rich. . . . .	Close the needle-valve a little before disconnecting current to the glowplug.
	②	★ Mismatch of glow plug and fuel. . . . .	Change fuel or glowplug.

**CARE AND MAINTENANCE**

**Please pay attention to the matters described below to ensure that your engine serves you well in regard to performance, reliability and long life.**

- As previously mentioned, it is vitally important to avoid operating the engine in conditions where dust, disturbed by the propeller, may be deposited on the engine and enter its working parts.
- Remember to keep your fuel container closed to prevent foreign matter from contaminating the fuel.
- Install a fuel filter to prevent dirt and dust in the fuel container from entering the fuel tank. O.S. Super Filters (L) and (S) are available as optional extras.
- Install an in-line fuel filter between the tank and carburetor to prevent dirt and dust in the tank from entering the carburetor.
- Clean these filters periodically.
- If these precautions are neglected, restriction of fuel flow may cause the engine to cut out, or the fuel/air mixture to become too lean causing the engine to overheat.
- The use of modern high-performance alcohol based model engine fuels, while promoting cooler running, improved anti-detonation combustion and increased power, have the disadvantage of causing corrosion due to the acid by-products of combustion. The use of nitromethane in the fuel can also contribute to the problem.

- Do not close the needlevalve and mixture control valve too far as this will cause a lean setting and over heating of the engine. This can, in turn, create nitromethane oxide leading to internal rusting of the engine. Always adjust the needlevalve slightly on the rich side of peak rpm.
- Do not leave unused fuel in the engine at the conclusion of a day's flying. Accepted practice is to cut off the fuel supply while the engine is still running at full throttle, then expel as much fuel residue as possible by turning the engine over 5-10 seconds with the electric starter. Finally, inject some after-run oil through the glowplug hole and turn the engine over several times by hand.
- When the engine is not to be used for some months (for example, as between flying seasons), a worthwhile precaution is to remove it from the airframe and, after washing off the exterior with alcohol (not gasoline nor kerosene), remove carefully the carburetor with intake pipe, glow plug and all silicone tubing and put them safely aside. Then, immerse the engine in a container of alcohol. Rotate the crankshaft while the engine is immersed. If foreign matter is visible in the alcohol, rinse the engine again in clean alcohol. Finally, shake off and dry the alcohol, and inject some after-run oil in the glowplug hole and rotate the crankshaft several times by hand. Reinstall the carburetor with intake pipe and glowplug on the engine and keep it in a dry place after putting in a vinyl bag.

**ENGINE EXPLODED VIEW**

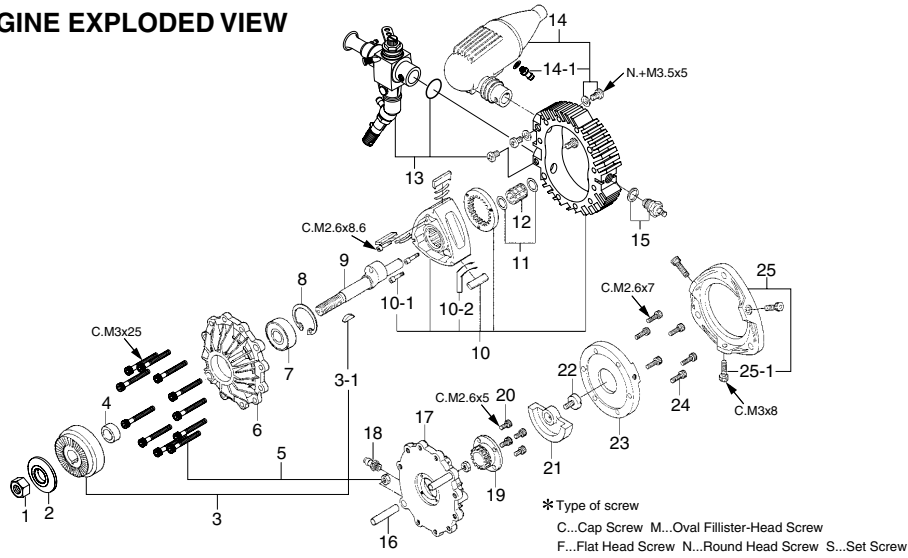

30

**OS ENGINE ENGINE PARTS LIST**

No.	Code No.	Description
1	23210007	Propeller Nut
2	23209003	Propeller Washer
3	41612020	Drive Hub
3-1	41826005	Woodruff Key
4	41625000	Shaft Spacer
5	41622020	Housing Assembly Screw Set
6	41601000	Front Housing
7	41614010	Crankshaft Ball Bearing (F)
8	41614100	Front Bearing Retainer
9	41604010	Eccentric Shaft
10	41602020	Rotor Housing Assembly
10-1	41820001	Rotor Gear Retaining Screw
10-2	41807004	Seal Spring (6pcs.)
11	41827002	Thrust Washer (2pcs.)
12	41815009	Rear Bearing
13	41618030	Carburetor Complete (Type 21G)
14	41635020	RE-2010 Silencer Assembly
14-1	22681957	Pressure Nipple (No.7)
15	71615009	Glow Plug Type F
16	41830000	Housing Assembly Tubular Dowels (2pcs.)
17	41603000	Rear Housing
18	22681953	Nipple No.1
19	41609000	Fixed Gear
20	41621000	Fixed Gear Retaining Screw (4pcs.)
21	41611000	Rear Counter Weight
22	45067319	Rear Counter Weight Retaining Screw
23	41616020	Rear Cover
24	41624010	Rear Cover Retaining Screw (6pcs.)
25	41633000	Engine Mount
25-1	41634010	Engine Retaining Screw (3pcs.)
	71531010	Non-Bubble Weight S

The specifications are subject to alteration for improvement without notice.

31



**CARBURETOR EXPLODED VIEW**

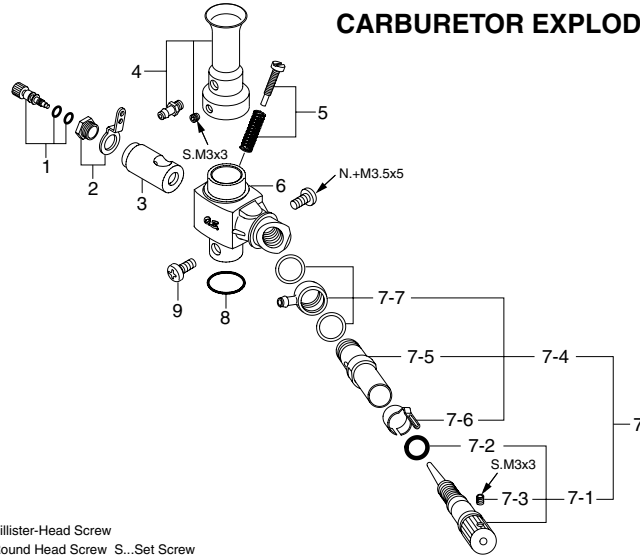





\* Type of screw  
 C...Cap Screw M...Oval Fillister-Head Screw  
 F...Flat Head Screw N...Round Head Screw S...Set Screw

**CARBURETOR PARTS LIST**

No.	Code No.	Description
1	41618600	Mixture Control Screw
2	41618410	Throttle Lever Assembly
3	41618200	Carburetor Rotor
4	41618300	Intake Tube
5	22681320	Throttle Stop Screw
6	41618120	Carburetor Body
7	41618930	Needle-valve Assembly
7-1	22681980	Needle Assembly
7-2	24981837	"O" Ring (2pcs.)
7-3	26381501	Set Screw
7-4	46181940	Needle-valve Holder Assembly
7-5	46181941	Needle-valve Holder
7-6	26711305	Ratchet Spring
7-7	46181950	Fuel Inlet
8	21015001	Carburetor Rubber Gasket
9	23081706	Carburetor Retaining Screw

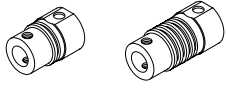
Specifications are subject to alteration for improvement without notice.

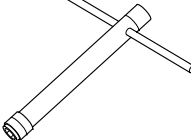
<p>■ <b>SPINNER NUT</b> 1/4"-28(L) (23024009)</p> 	<p>■ <b>LONG PROPELLER NUT SETS</b> (73101000)</p> 	<p>■ <b>NEEDLE VALVE EXTENSION CABLE SET</b> (72200080)</p> 	<p>■ <b>SILENCER EXTENSION ADAPTORS SET</b> (41651300)</p> <p>Adaptor L12    Adaptor L20</p>  <p>M3.5x6 (4pcs.)</p>
<p>■ <b>SUPER FILTER (L)</b> (72403050)</p> 	<p>■ <b>CAP SCREW SETS</b> (10pcs./sets)</p> <ul style="list-style-type: none"> <li>● M2.6x5 (79871010)</li> <li>● M3x8 (79871110)</li> <li>● M2.6x7 (79871020)</li> </ul> 	<p>■ <b>SPRING WASHER</b> (20pcs.)</p> <ul style="list-style-type: none"> <li>● 3.5(Black) (79872035)</li> </ul>	<p>■ <b>LONG SOCKET WRENCH WITH PLUG GRIP</b> (71521000)</p> 

The specifications are subject to alteration for improvement without notice.

**SPECIFICATIONS**

Dimensions(mm)

■ Displacement	4.97 cc (0.303 cu.in.)
■ Bore	_____
■ Stroke	_____
■ Practical R.P.M.	2,500-18,000 r.p.m.
■ Power output	1.1 ps / 1.12 hp / 17,000 r.p.m.
■ Weight	450 g (15.88 oz.) (Silencer and Engine Mount are contained.)

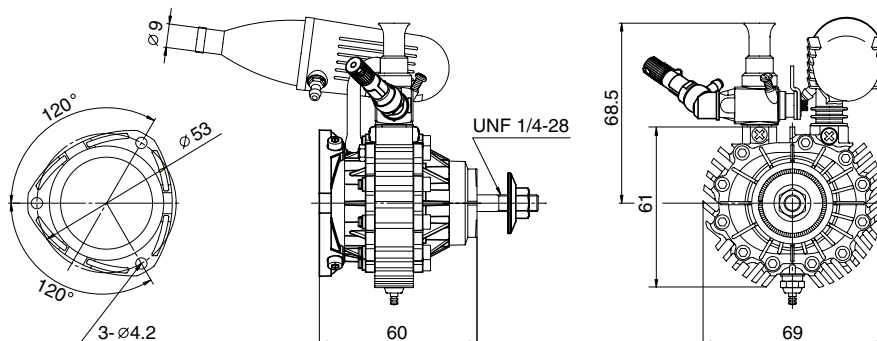



**O.S. ENGINES** MFG.CO.,LTD.  
URL : <http://www.os-engines.co.jp>

6-15 3-Chome Imagawa Higashisumiyoshi-ku  
Osaka 546-0003, Japan TEL. (06) 6702-0225  
FAX. (06) 6704-2722