

It is of vital importance, before attempting to operate your engine, to read this 'SAFETY INSTRUCTIONS AND WARNINGS' leaflet and to strictly adhere to the advice contained herein. Also, please read through the instruction leaflet or manual supplied with the engine, so as to familiarize yourself with the controls and other features of the engine.

Keep this leaflet and the engine instructions in a safe place so that you may readily refer to them whenever necessary. It is suggested that any in-structions supplied with the boat, radio-control equip-ment, etc., are accessible for checking at the same time.

INDEX

SAFETY INSTRUCTIONS AND WARNINGS ABOUT YOUR O.S. ENGINE	1
NAMES OF ENGINE PARTS, INSTALLATION, SILENCER, GLOW PLUGS, FUEL, PROPELLER, CYLINDER HEAD GASKET	2
STARTING, ADJUSTING THE CARBURETTOR, RUNNING-IN, CARE AND MAINTENANCE, GUARANTEE	3
CARBURETTOR EXPLODED VIEWS, PARTS LIST	4



(glowplug, joint, flywheel and exhaust header shown are optional extra.)

SPECIFICATIONS

Displacement	7.45cc (0.455cu.in.)	Practical R.P.M.	2,500-28,000
Bore	22.0mm (0.866in.)	Power output	2.5PS/23,000r.p.m.
Stroke	19.6mm (0.772in.)	Weight	445g(15.6oz.)

SAFETY INSTRUCTIONS AND WARNINGS ABOUT YOUR O.S. ENGINE

Remember that your engine is not a "toy", but a highly efficient internal-combustion machine whose power is capable of harming you, or others, if it is misused or abused.

As owner, you, alone, are responsible for the safe operation of your engine, so act with discretion and care at all times.





If at some future date, your o.s. engine is acquired by another person, we would respectfully request that these instructions are also passed on to its new owner.

■ The advice which follows is grouped under two headings according to the degree of damage or danger which might arise through misuse or neglect.

⚠ WARNINGS Cover events which might involve serious (in extreme circumstances, even fatal) injury.

⚠ NOTES Cover the many other possibilities, generally less obvious sources of danger, but which, under certain circumstances, may also cause damage or injury.

⚠ WARNINGS

- Never touch, or allow any object to come into contact with, the rotating propeller. 
- Model engine fuel is poisonous. Do not allow it to come into contact with the eyes or mouth. Always store it in a clearly marked container and out of the reach of children. 
- Model engine fuel is also highly flammable. Keep it away from naked flame, excessive heat, sources of sparks, or anything else which might ignite it. Do not smoke or allow anyone else to smoke, near to it. 
- Never operate your engine in an enclosed space. Model engines, like automobile engines, exhaust deadly carbon-monoxide. Run your engine only in an open area. 
- Model engine generate considerable heat. Do not touch any part of your engine until it has cooled. Contact with the muffler(silencer), cylinder head or exhaust header pipe, in particular, may result in a serious burn. 

⚠ NOTES

- This engine was designed for model boat. Do not attempt to use it for any other purpose.
- Mount the engine in your model securely, following the manufacturers' recommendations, using appropriate screws and locknuts.
- Fit an effective silencer (muffler). Frequent close exposure to a noisy exhaust (especially in the case of the most powerful high-speed engines) may eventually impair your hearing and such noise is also likely to cause annoyance to others over a wide area.
- For their safety, keep all onlookers (especially small children) well back (at least 12 feet or 4 metres) when preparing your model for running.
- Take care that the glowplug clip or battery leads do not come into contact with the propeller or any other rotating parts. Also check the linkage to the throttle arm.
- When starting your engine, use an electric starter. The wearing of safety glasses is also strongly recommended.
- When you carry the model after starting the engine, be especially cautious. Keep the propeller and other rotating parts away from you.
- Adjust the throttle linkage so that the engine stops when the throttle stick and trim lever on the transmitter are fully retarded. Alternatively, the engine may be stopped by cutting off the fuel supply. Never try to stop the engine physically.
- Warning! Immediately after a glowplug-ignition engine has been run and is still warm, conditions sometime exist whereby it is just possible for the engine to abruptly restart if the glowplug battery being reconnected.

The MAX-46VX-M and 46VX-M(ST) are high-performance engines designed strictly for power boat racing. The MAX-46VX-M(ST) is especially designed to use the straight fuel, while the MAX-46VX-M is designed to use the fuel containing nitromethane - i.e. the only difference between two versions is difference of combustion chamber shape.

CATIONS

- This engine is designed for power boat racing experts, not for beginners who are not familiar with the handling of the power boat racing engine.
- We do not recommend running your boat on the seas, or in any other salt-water environment. Under such conditions, it is difficult to prevent the engine from becoming corroded and, eventually, inoperative.

NAMES OF ENGINE PARTS

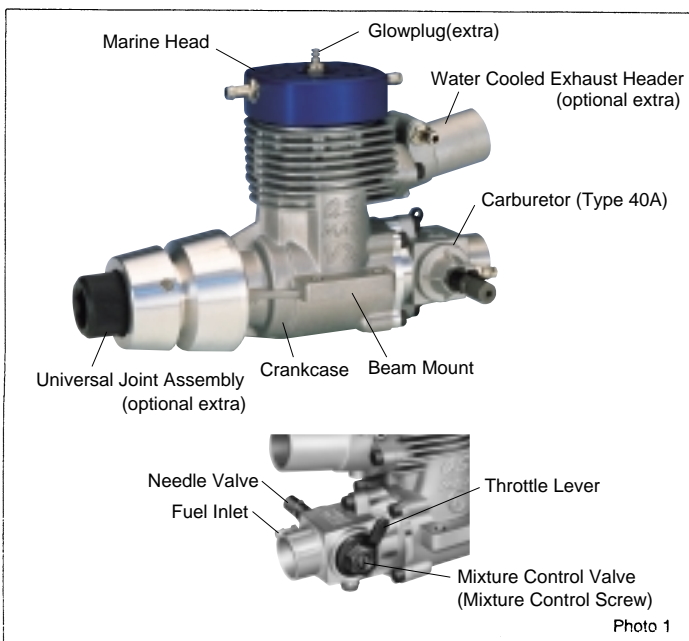

INSTALLATION

- Make sure that the engine sits squarely in the enginebed or mount. If necessary, trim or modify the mount(see sketch) so that only the under-surfaces of the engine's mounting lugs are in contact with the bearer surfaces. Poor installation may not only cause erratic running and loss of power, it may also damage the engine itself by distorting the crankcase, bearings, etc.
- For the highest performance, we recommend that the engine mount and its surroundings are as heavy and as rigid as possible.
- Make sure that the engine bearers are parallel and that their mounting surfaces are in the same plane. Use 3mm steel screws, such as Allen type, with locknuts, for bolting the engine to the bearers. If the holes in the mounting beams do not align perfectly with the engine's mounting lugs, enlarge them slightly with a needle file so that the fixing screws go in perfectly. In this case, make sure that no filings, or other foreign matter, are allowed to enter the engine or carburettor.
- The distance between the carburettor air intake and any bulkhead near the engine should be at least 15mm(0.59"), otherwise the induction efficiency will be reduced.
- Clean the model's "engine room" before installing the engine, in order to eliminate the risk of foreign matter such as sandpaper residue, glass wool, dust, etc., being drawn through the carburettor.

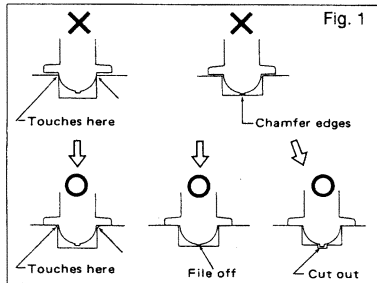

SILENCER

As these racing type O.S. marine engines have been designed primarily for use with a tuned length exhaust silencer system, a conventional silencer is not supplied. Any of the tuned silencers currently available for .65 to .90 cu.in. engines may be used. Silicone tubing may be employed to connect the silencer to the exhaust adaptor or header pipe. However, remember that, if silicone tubing is exposed directly to exhaust gases, it will deteriorate more quickly. Therefore, when tuning exhaust length to required operating r.p.m., try to limit any exposed length of silicone tube, between the exhaust adaptor and silencer, to not more than 3-5mm (or 1/8"-3/16").

Note:

When a tuned silencer is set to be tuned best at full throttle, the engine will not get out of tune and keep running at high r.p.m. when close the throttle from full throttle to reduce the speed for a turn, while the mixture gets lean to the degree of throttle closing. This may cause connecting rod seizure which will result in connecting rod failure. In order to prevent this, a) close the throttle to idling to get the engine out of tune, then open the throttle to the required position or a) set the

tuned silencer a little longer so that the engine may get out of tune easily when the throttle is closed from full throttle.

Note: Be sure to use a pressurized fuel system.

WARNING!

Model engine generate considerable heat. Do not touch any part of your engine until it has cooled. Contact with the muffler(silencer), cylinder head or exhaust header pipe, in particular, may result in a serious burn.

GLOW PLUGS

The type of glow plug used may affect the performance of the engine quite considerably, under different atmospheric conditions and on different fuels. Select the best one by practical tests from available long reach type glow plugs. Recommended O.S. plug is No.8 or R5. When engines are run at very high speeds and on high-nitro fuels, glowplug elements do not last so long. Therefore, have spare plugs readily available when racing.

FUEL (IN CASE OF CONTAINING NITROMETHANE)

Use only top quality model two-stroke engine fuel containing not less than 18% lubricant. These engine can be run on either low or high nitromethane content fuels, i.e. from mild mixtures containing a few percent of nitromethane, up to high-speed racing fuels containing 40%, or more, of nitromethane. Generally, power output is increased - up to a certain point - as the nitromethane content of the fuel containing more nitro if necessary. When the nitro content of the fuel is increased. As a starting point, we recommend a fuel containing 10-20% nitromethane, changing to a fuel is increased or the brand of fuel is changed, it is advisable to run the engine with a richer needle-valve setting, initially, so that the optimum setting for the new fuel may be rechecked as described in the RUNNING-IN paragraph. Please note that, with high-nitro fuels, although power may be increased for competition purposes, glowplug elements do not last so long and engine life will be shortened.

WARNING!

Model engine fuel is poisonous. Do not allow it to come into contact with the eyes or mouth. Always store it in a clearly marked container and out of the reach of children.

Model engine fuel is also highly flammable. Keep it away from naked flame, excessive heat, sources of sparks, or anything else which might ignite it. Do not smoke or allow anyone else to smoke, near to it.

PROPELLERS

Suggested propellers are shown in the table. Use well balanced propellers

For Deep Vees		For Hydroplanes	
Diameter(mm)	P/D ratio	Diameter(mm)	P/D ratio
48~50	1.0~1.3	50~58	1.4~1.8

WARNING!

Never touch, or allow any object to come into contact with, the rotating propeller.

CYLINDER HEAD GASKET

ENGINE	Nitromethane content	Head-gasket	
46VX-M(ST)	STRAIGHT (0%)	TWO(Factory set) (0.1mm+0.1mm)	Summer time
		ONE (0.1mm)	Winter time
46VX-M	MORE THAN 40%	TWO(Factory set) (0.1mm+0.1mm)	Summer time
	LESS THAN 40%	ONE (0.1mm)	Winter time

It may be necessary to lower the compression ratio when a tuned silencer is set at high-tune(e.g. in heat race), or if glowplugs tend to burn out repeatedly. In such cases, the fitting of an extra cylinder-head gasket is recommended.

STARTING

- ◆ Set the needle-valve. Turn the needle-valve clockwise slowly, without forcing until it stops. Then, turn the needle-valve 1- 1/2 turns counter-clockwise.
- ◆ Open the throttle.

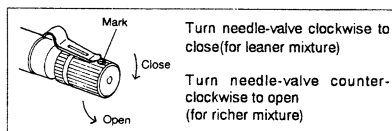

Turn needle-valve clockwise to close(for leaner mixture)
Turn needle-valve counter-clockwise to open (for richer mixture)

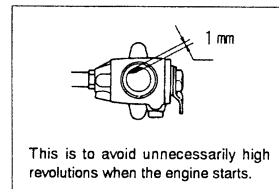

- ◆ Heat the glowplug. Connect the battery leads.

- ◆ Starting the engine

Fit a starter belt at the flywheel groove and starter cone groove. Depress the starter switch and immediately pull up the starter so that the belt may come into contact with the flywheel. When the engine fires, release the starter from the belt immediately.

Attention:

If you apply the starter with the engine flooded or placing your finger over the carburettor intake, the connecting rod may bend and damage the engine.

- ◆ Adjusting the needle-valve
Adjust the needle-valve to an optimum setting while actually running your model.
- ◆ How to stop the engine.
Close the throttle fully to cut off air supply.

ADJUSTING THE CARBURETTOR

- This carburettor is not provided with a screw for setting the throttle opening at the idling position. Instead, the throttle is set up as follows:
Connect the throttle lever linkage so that the throttle rotor is (a) fully open when the transmitter throttle stick is fully advanced and (b) fully closed when the throttle stick is fully retarded.
Adjustment of the throttle rotor opening at the idling position can then be made with the throttle trim lever on the transmitter.
- Advance the throttle trim lever so that the throttle rotor opens approximately 1mm from the fully closed position as sketched.
Set the needle-valve $1\frac{1}{2}$ turns (depending on the size of the engine and type of fuel) open from the fully closed position, and start the engine.

WARNING!

When a watercooled marine engine is started on shore avoid running it at high r.p.m. without load, either by keeping the throttle in the idling position, or by opening the needle-valve to reduce speed. Although the engine is designed to run at high r.p.m. even when new, such components as the cylinder, piston, connecting-rod, etc. will be seriously damaged if they are allowed to become overheated.

- Put the boat on the water before opening throttle and then adjust the Needle-Valve for the approximate best setting.
- The Mixture Control Screw is for adjusting fuel mixture strength at part throttle and idling speeds. Having set the needle-valve as detailed above, close the throttle. The engine should idle continuously and steadily. (If it stops immediately, first try advancing the throttle trim lever on the transmitter to raise the idling speed a little.)
 - If, however, the engine idles unevenly and hesitates when the throttle is re-opened, it is probable that the idling mixture is too rich. Check this by closing the throttle again and reopening it after about 10 seconds. If the engine now puffs out a good deal of smoke and hesitates or even stops, it will be necessary to close the Mixture Control Screw. Therefore, turn it a few degrees clockwise. (Turn the Mixture Control Screw in steps of about 20 degrees only, re-checking the running qualities each time.)
 - If, instead of being set too rich, the Mixture Control Screw is set too lean, the engine will stop when the throttle is closed, or will lose speed while idling and then cut out abruptly (without smoking) when the throttle is opened again. In this case, turn the Mixture Control Screw counter-clockwise.

Mixture Control Screw adjustment is not critical and, by remembering the symptoms of rich and lean running quoted above, it is a simple matter to establish the best setting.
The correct mixture for part-throttle (medium speed) running is automatically controlled by the Mixture Control Screw when it has been adjusted to the best idling setting.

- If, after carrying out mixture adjustments, the idling speed is found to be too high, the throttle trim lever should be moved downward until the desired idling speed is achieved.

Note:

Once the correct carburettor settings have been established, it should be unnecessary to alter them. Such slight needle-valve adjustments as may be required to cope with variations in atmospheric conditions, will not normally affect the other controls. A small readjustment may be required if the fuel and/or plug are changed to different types.

REALIGNMENT OF MIXTURE CONTROL SCREW

The Mixture Control Screw is factory set at the approximate best position. If, however, the Mixture Control Screw has been tampered with, or moved accidentally, set it at the original position as follows. Screw in the Mixture Control Screw until stops while keeping the rotor fully closed. Then, unscrew $2\frac{1}{2}$ turns. This is the original position of the Mixture Control Screw.

CARBURETTOR CLEANLINESS

The minute particles of foreign matter, that are present in any fuel-can, may, by accumulating and partially obstructing fuel flow, cause engine performance to become erratic and unreliable. O.S. 'Super Filters' (large and small) are available, as optional extras, to deal with this problem. One of these filters, fitted to the outlet tube inside your refueling container, will prevent the entry of foreign material into the fuel tank. It is also recommended that a good in-line filter be installed between the tank and carburettor. Do not forget to clean the filters regularly to remove dirt and lint that accumulate on the filter screens. Also, clean the carburettor itself occasionally.

It is also advisable to check the cleanliness of the carburettor periodically. Using the wrench supplied, remove the needle-valve holder from the carburettor body and wash out the interior to remove any minute particles that may have escaped through the filters.

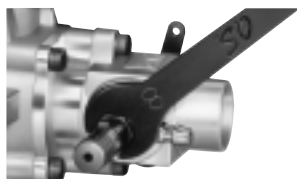

Remove needle-valve holder with an 8mm wrench

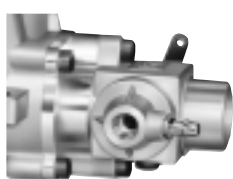

Dirt and fibrous matter mostly accumulate here

RUNNING-IN ("Breaking-In")

It has been observed that some modellers consider the running in of an engine to be complete after simply running it on a bench mount for a time. This is incorrect. For the best performance, the engine should also be run-in under the same conditions as when it is put to full use. Run-in your engine after installing it in your boat, in the following way.

- For the initial stage, set the needle-valve as much on the rich side as possible without badly affecting the running of the boat. Then, with each successive run, gradually and progressively re-set the needle-valve for increased r.p.m. Set the needle-valve on the rich side for at least the first 10 to 15 runs. If it is intended to use high nitromethane fuels, begin by using one in which the nitromethane content is limited to between 10 to 20 percent.
- When the engine is capable of running at the optimum setting without over heating or loss of power, a fuel of higher nitromethane content may be used. However, each time the nitromethane percentage is increased, always take the precaution of restarting with a rich needle setting for a further trial run.

WARNING:

When the engine is installed in the model, avoid running it at high r.p.m. without load just after the engine is started on shore, either by closing the throttle or by opening the needle-valve to reduce speed. Although this engine is designed to run at high r.p.m. even when new, such components as the cylinder, piston, connecting rod, etc. will be seriously damaged if they are allowed to become over-heated. Re-adjust the throttle and/or needle-valve immediately before the model is put in the water.

Note:

The use of a different fuel particularly one containing more, or less, nitromethane and/or a different type or proportion of lubricating oil, is likely to call for some readjustment of the Needle-Valve. Remember that, as a safety measure, it is advisable to increase the Needle-Valve opening by an extra half-turn counter-clockwise, prior to establishing a new setting. The same applies if the silencer type is changed. A different silencer may alter the exhaust pressure applied to the fuel feed and call for a revised Needle-Valve setting. The use of a different glowplug, or changes to the main rotor and its pitch angles may also require compensating carburettor readjustments.

CARE AND MAINTENANCE

- At the end of each operating session, drain out any fuel that may remain in the fuel tank. Afterwards, energize the glowplug and try to restart the engine, to burn off any fuel that may remain inside the the engine. Repeat this procedure until the engine fails to fire. Try to eject residue while the engine is still warm.
- Follow this procedure with the injection of some corrosion -inhibiting oil, rotating the engine by hand to distribute the oil to all working parts. Alternatively, an electric starter may be used if the glowplug is removed. (In this case, hold a clean cloth over the cylinder-head to catch surplus oil that may spray from the glowplug-hole.)

Note:

Corrosion-inhibiting oil should be directed into the engine's crankcase, but not into the carburettor itself, as this may cause deterioration of the O-ring seals inside the carburettor mechanism. These procedures will reduce the risks of corrosion or difficult starting after a period of storage.

- Finally, when cleaning the exterior of the engine, use methanol or kerosene. Do not use gasoline or any solvent that might damage the silicone fuel tubing.

GUARANTEE

This engine is constructed from the very best materials available and to the very highest engineering standards, using the most advanced precision machinery. However, the extremely high stresses imposed by boat racing operation under very severe conditions, stresses which, exacerbated by the use of powerful fuels containing very high concentrations of nitromethane, constitute hazards which are beyond a manufacturer's control. Accordingly, we regret that it is not possible to extend our usual warranty terms to this particular engine-i.e. no guarantee is offered against material wear, or damage resulting therefrom, in actual use.

Needle Control Lever

By fitting the Needle Control Lever (optional extra) to the needle knob, the needle-valve can be adjusted by radio-control. Before fitting the Lever, remove the needle ratchet spring.

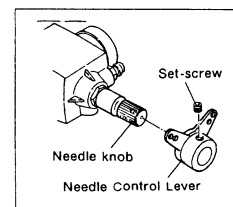

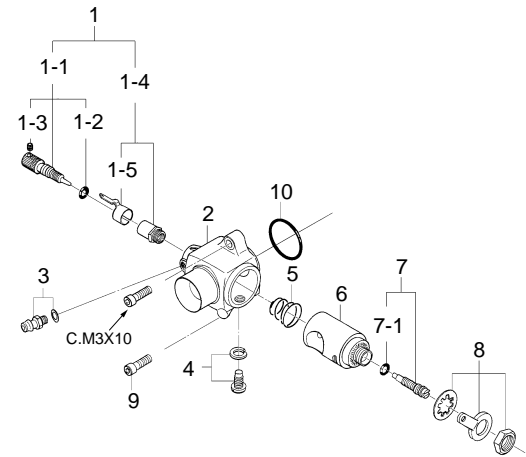
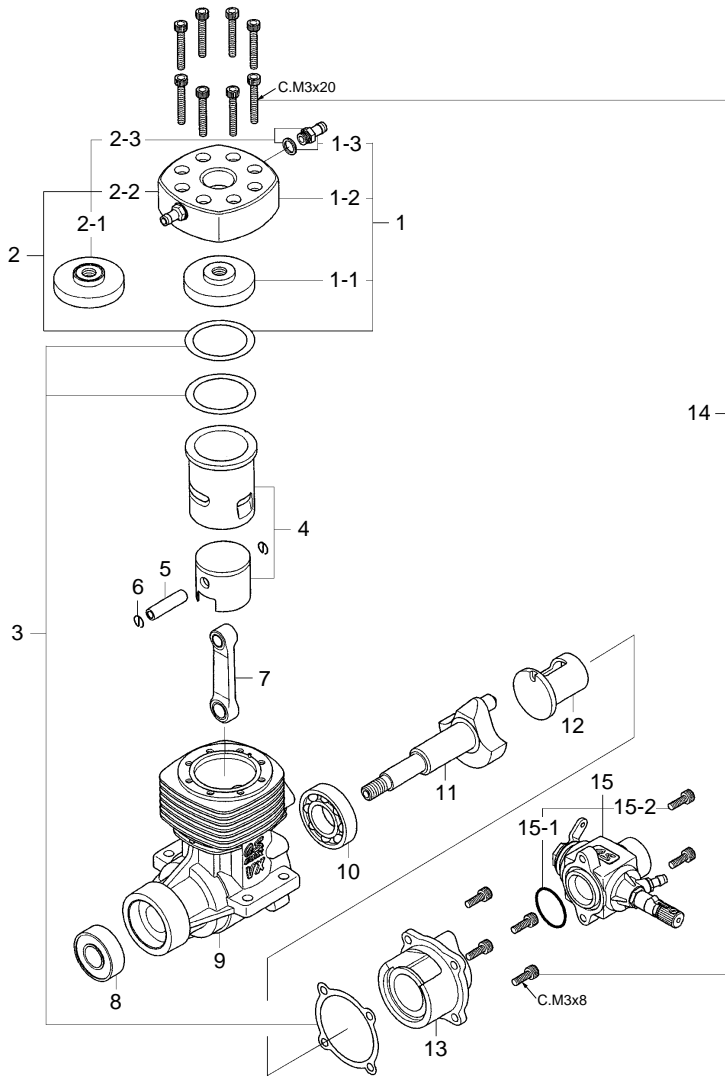

* Type of screw
 C...Cap Screw M...Oval Fillister-Head Screw
 F...Flat Head Screw N...Round Head Screw S...Set Screw

No.	Code No.	Description
1	25581900	Needle Valve Assembly
1-1	22681980	Needle
1-2	24981837	"O" Ring (2pcs.)
1-3	26381501	Set Screw
1-4	27381940	Needle Valve Holder Assembly
1-5	26711305	Ratchet Spring
2	25581100	Carburetor Body
3	22681953	Fuel Inlet
4	25581220	Rotor Guide Screw
5	28281500	Rotor Spring
6	25581200	Carburetor Rotor
7	28281300	Mixture Control Screw
7-1	27881820	"O" Ring
8	28281400	Throttle Lever Assembly
9	25581700	Carburetor Retaining Screw
10	25515000	Carburetor Rubber Gasket

No.	Code No.	Description
1	25541000	Marine Head Assembly (46VX-M)
1-1	25541100	Marine Head (A)
1-2	25541200	Marine Head (B)
1-3	24025923	Nipple No.2
2	25541010	Marine Head Assembly (46VX-M(ST))
2-1	25541110	Marine Head (A-ST)
2-2	25541200	Marine Head (B)
2-3	24025923	Nipple No.2
3	25514000	Gasket Set
4	25503000	Cylinder & Piston Assembly
5	25306019	Piston Pin
6	24517000	Piston Pin Retainer(2pcs.)
7	25505000	Connecting Rod
8	24530000	Crankshaft Ball Bearing (Front)
9	25501000	Crankcase
10	27330010	Crankshaft Ball Bearing (Rear)
11	25502000	Crankshaft
12	25516000	Rear Drum
13	25501800	Rear Housing
14	25513000	Screw Set
15	25581000	Carburetor Complete 40A

O.S. GENUINE PARTS & ACCESSORIES

Code No.	Description
71804020	Flywheel No.4C
25343108	Marine Universal Joint Assembly (4.5mm)
25345206	Marine Universal Joint Assembly (5.0mm)
25345319	Marine Universal Joint Assembly (3/16"mm)
25326600	Water Cooled Exhaust Header
72101260	Exhaust Header Pipe
28282300	Needle Cotrol Lever
71521000	Long Socket Wrench With Plug Grip

The specifications are subject to alteration for improvement without notice.

O.S. ENGINES MFG.CO.,LTD.

6-15 3-Chome Imagawa Higashisumiyoshi-ku
 Osaka 546-0003, Japan TEL. (06) 6702-0225
 FAX. (06) 6704-2722
 URL : <http://www.os-engines.co.jp>